



Converter Accessory Corporation

201 Alpha Road, Wind Gap, PA 18091

www.handleyourweb.com
Email: cac@epix.net

Phone: (800) 433-2413
(610) 863-6008

Fax: (800) 709-1007
(610) 863-7818



- Save back injuries
- Stop roll damage
- New roll handling device

Lift 'N' Turn Assembly

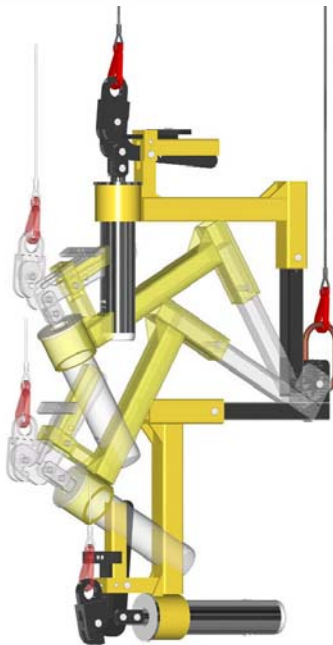
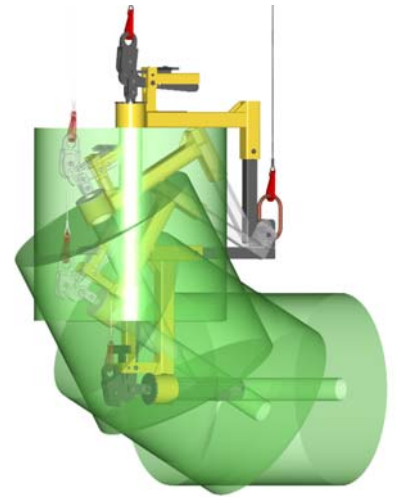
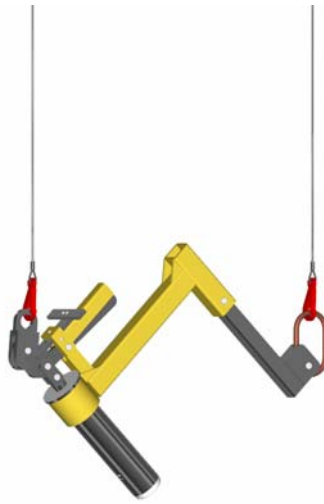
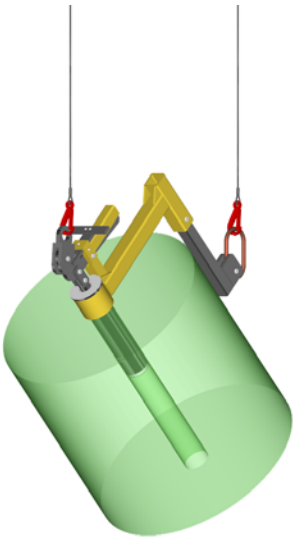

The Lift 'N' Turn assembly with center lift is the **safest, most effective, cost efficient** and **durable** way to lift, move, position and place rolls on the market today. The flexible 2-point suspension system allows for easy alignment with roll core I.D.'s from 3" to 20". An important safety design incorporated in the Center Lift; it is impossible to disengage while supporting up to 1,000 lbs., yet the handle lifts easily when release is desired. The Lift 'N' Turn assembly enables true horizontal and vertical roll positioning, 360° North to South effortless roll rotation – to get your rolls where you want them. The Lift 'N' Turn grabs rolls by the core I.D. preventing material damage and designs are available to turn the roll in any direction.



Converter Accessory Corporation

201 Alpha Road, Wind Gap, PA 18091

www.handleyourweb.com
Email: cac@epix.net

Phone: (800) 433-2413
(610) 863-6008

Fax: (800) 709-1007
(610) 863-7818

Center Lift Ideal for hoists, jibs and bridge cranes

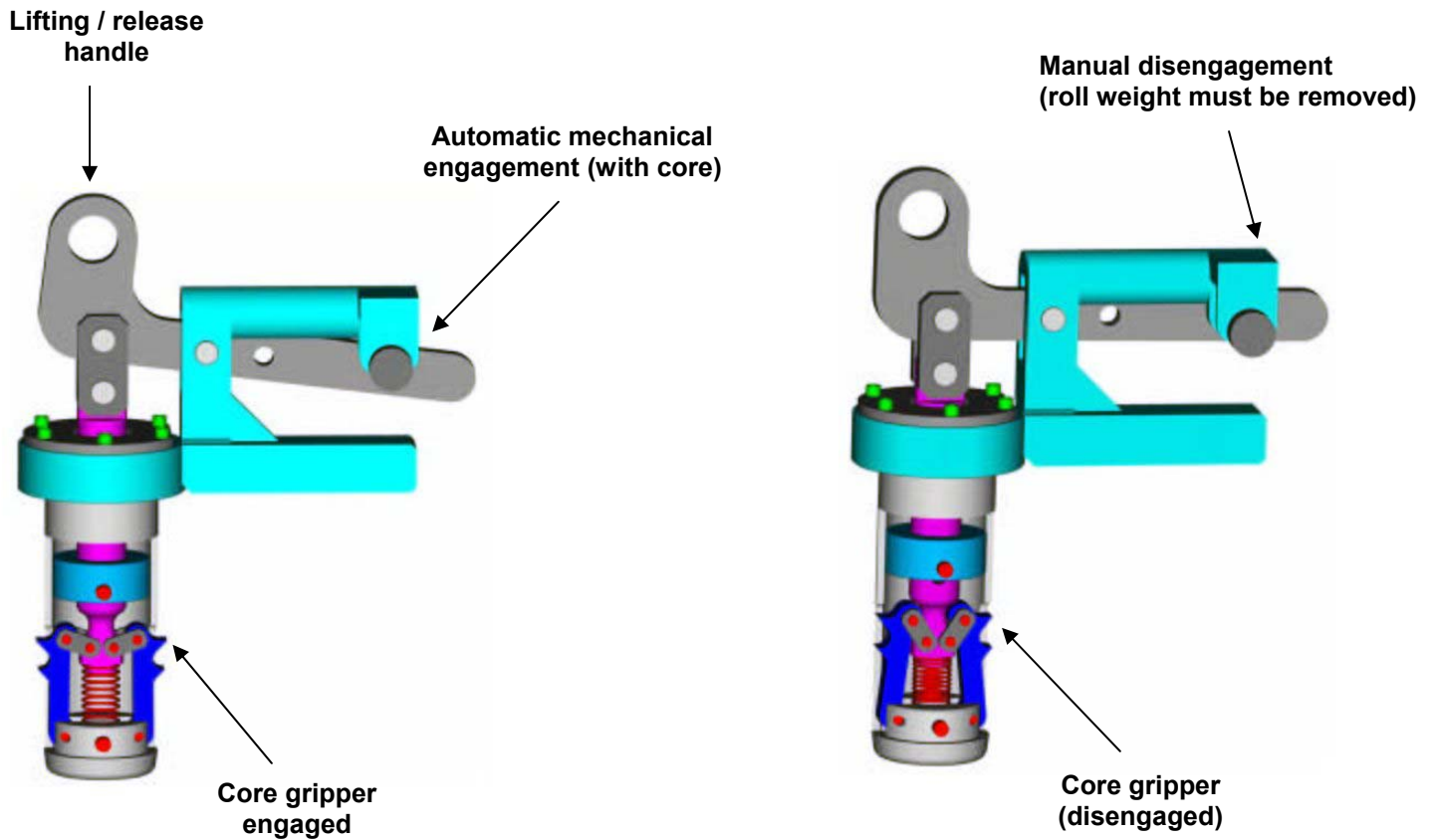

- Safe & simple to use
- Available for 3" to 20" I.D. core sizes
- Heavy duty construction is virtually maintenance free
- Handle lifts with ease to disengage
- Positive gripping action in any core
- Cannot disengage while supporting weight