

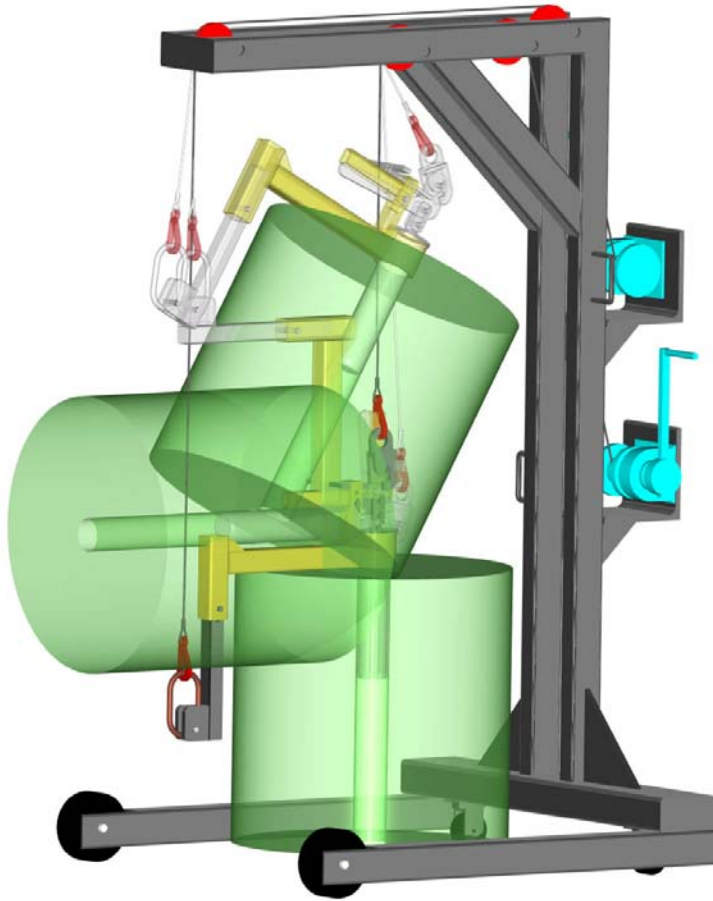

Rol-handIR™ Model PH1 Portable Hoist Roll Handling Systems



Rol-handIR™ Model PH1 systems lift and turn rolls from horizontal to vertical, vertical to horizontal and transport and place them on pallets, cantilevered unwind shafts or other production, shipping or storage areas.

The Rol-handIR Model PH 1 is a cost effective exceptionally easy to operate solution for handling rolls up to 1000 lbs. in a wide range of widths and diameters. Model PH 1, an entirely self-contained, floor-based moveable system that complements I-beam-based Rol-handIR models for rolls to 1000 lbs. Model PH 1 is available in mechanical or battery powered electrical configurations. The self-contained Rol-handIR Model PH 1 does not require overhead equipment, fork truck or any other additional handling equipment. It is a rugged, compact system able to lift and turn rolls from horizontal to vertical, vertical to horizontal and transport to place them on pallets, cantilevered unwind shafts or other production, shipping or storage areas.

The Rol-handIR Model PH1 mechanical version features simple hand operated hoists while the electrically powered system features an ergonomically designed remote pendant controls. Both versions are safe to operate, featuring locking casters, two point, flexible suspension and mechanical core locking. The system's true horizontal and vertical roll turning capabilities reduce the possibility of roll edge damage during handling. CAC's unique center lift probe, standard with Rol-handIR systems, also contributes to protecting roll edge integrity. Rol-handIR is a super easy to use solution that goes to the heart of roll handling difficulties without expensive frills, flourishes and trimmings. The complete unit can be shipped and put to work immediately. Its rugged construction ensures a long, productive life.



Converter Accessory Corporation

201 Alpha Road, Wind Gap, PA 18091

Phone: (800) 433-2413

(610) 863-6008

Fax: (800) 709-1007

(610) 863-7818

www.handleyourweb.com

Email: cac@epix.net

Features & Benefits:

- True horizontal and vertical roll turning - eliminating the possibility of roll edge damage
- Rolls are gripped by the core with CAC's exclusive Center Lift probe – eliminating damage to rolls outer layers
- Mechanical core locking ensures safe operation
- Simple hand operated hoists
- Battery operated electric hoists with ergonomically designed remote pendant are available
- Lift, turn and transport rolls where you need them - lift vertically positioned rolls off pallets, turn them to horizontal position, place onto cantilevered unwind shaft or floor - lift horizontally positioned rolls off cantilevered unwind shaft or floor, turn roll vertical, place onto pallet for shipping
- Accommodates varying roll widths and diameters
- Standard units available up to 1,000 lbs. rolls
- Super easy to use-two point, flexible suspension system
- No overhead equipment, fork truck or other handling equipment needed
- Available in manual or motorized models
- Rugged, compact frame design mounted on locking casters – virtually maintenance free
- Systems are shipped complete for immediate use

