



Converter Accessory Corporation
www.converteraccessory.com



Pneumatic Conveying Systems
www.foxtrimaway.com



Three Venturi Sizes Available

FX1 Venturi

FX2 Venturi

FX3 Venturi



For more information on our venturi's, visit:
www.converteraccessory.com/components

Which Venturi is right for me?

FOX TrimAway® venturi's are designed for efficient removal of flexible to semi-rigid materials, such as web edge trim, pieces and matrix and are designed to operate in conjunction with regenerative type blowers. Air flow thru each venturi can vary greatly depending on the blower size with which it is teamed; CAC engineers will assist each customer with the proper venturi / blower combination for your application. Venturi's are normally tuned for maximum suction and air flow prior to shipment to the customer; however, all venturi models are adjustable in the field. All venturi models can be PTFE lined where exposed pressure sensitive adhesives must be handled.

FX1 Venturi - This venturi is generally used for narrow trim (up to 1") and relatively short conveying distances (up to 50'). FX1 venturi's are typically used for flexible trim at relative slow to intermediate speeds. The FX1 is approximately 11.5" long, 1.5" diameter at the suction and 2" diameter at the discharge (pressure). Typical regenerative blower sizing is between .5 HP to 2 HP.

FX2 Venturi - This venturi is our mid-size venturi and is our most popular model. It can handle trim up to 2" wide (sometimes wider depending on the trims flexibility). Conveying distances can range from 10' to approximately 100'. FX2 venturi's can handle trim that is flexible to semi-rigid. Trim speed can vary from just a few feet per minute up to over 4,000 feet per minute. The FX2 is approximately 24" long, 2.5" diameter at the suction and 4" diameter at the discharge (pressure). Typical regenerative blower sizing is between 2 HP to 10 HP.

FX3 Venturi - This is our largest model of venturi. It can handle trim over 3" wide. Conveying distances can range from 10 feet to well over 100 feet. FX3 venturi's can handle trim that is flexible to semi-rigid. Trim speed can vary from just a few feet per minute to over 6,000 feet per minute. The FX3 is approximately 29" long, 4" diameter at the suction and 5" diameter at the discharge. The inside diameter tapers down to 3". Typical regenerative blower sizing is between 5 HP up to 20 HP.



Venturi Accessories

For more information on these components, visit:
www.converteraccessory.com/components

Pneumatic Conveying Systems
www.foxtrimaway.com

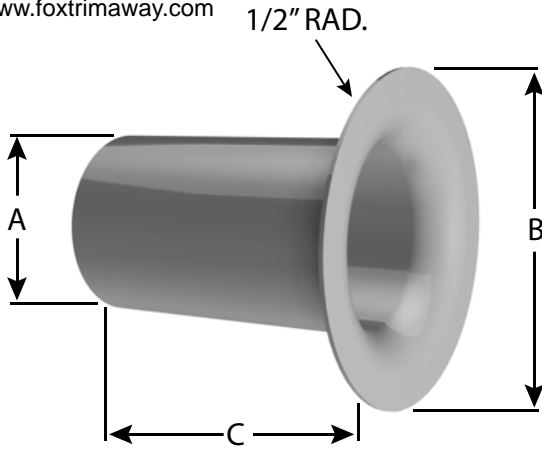

Pick Up Nozzles

FOX TrimAway pick up nozzles are trumpet shaped to eliminate the possibility of trim snags. Standard construction is epoxy painted (gray) steel for long life. Pick up nozzles come in three sizes to fit perfectly with our unique venturi systems but they also work well with almost any pneumatic trim removal system.

Pick Up Nozzle	A	B	C
1.50"	1.50	2.75	4.50
2.50"	2.50	4.25	4.50
4.00"	4.00	6.00	7.00

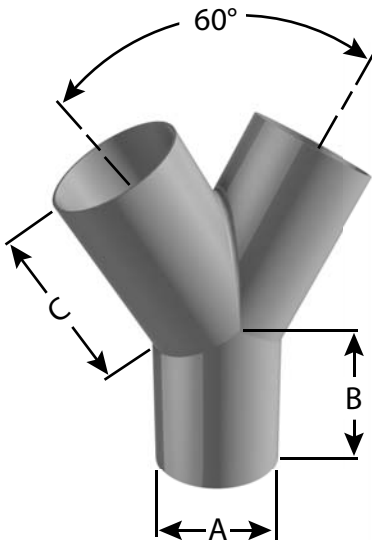

Y Connector

Y Connectors from FOX TrimAway are typically used for connecting two pick points to feed them into one venturi. Standard construction is epoxy painted (gray) steel for long life. Y connectors come in four sizes that are engineered for use with FOX TrimAway pneumatic trim removal systems. However, they work equally well with almost any trim removal system.

Y Connector	A	B	C
1.50"	1.50	2.50	2.50
2.00"	2.00	3.25	2.75
2.50"	2.50	3.00	3.50
4.00"	4.00	5.00	7.00

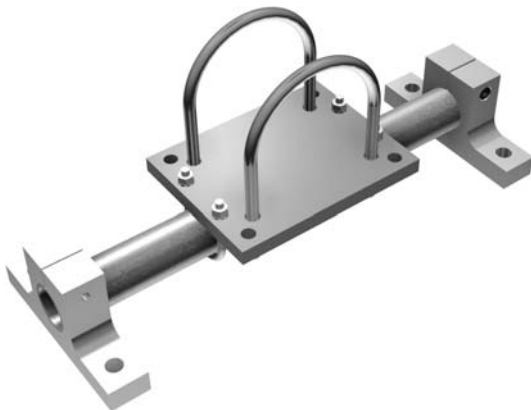

Venturi Mounting Bracket

The optional venturi mounting bracket will allow for easy mounting of any of the FOX TrimAway venturis. These brackets are available in three unique sizes, each designed to fit the FX1, FX2 and FX3 venturis.



Converter Accessory Corporation

201 Alpha Road, PO Box 188, Wind Gap, PA 18091-0188

www.converteraccessory.com
sales@converteraccessory.com

Phone: 800-433-2413
 610-863-6008

Fax: 800-709-1007
 610-863-7818