



Slitting Systems



Shear Cut Edge Trim Assembly



- Top and bottom blades are mounted on one assembly to provide simultaneous movement
- Top blade has automatic air operated side loading
- Bottom blade can be driven
- Used for shear cut slitting applications
- Ideal for use with all types of materials
- Compact design
- Fits in any location on existing equipment
- Carriage travel can accommodate narrow to wide web width variations
- Can be used with existing trim removal system
- Integral CAC pneumatic trim removal systems are available
- No special framework or customer modifications required
- Easy installation—four mounting holes

Inline Slitting Assembly

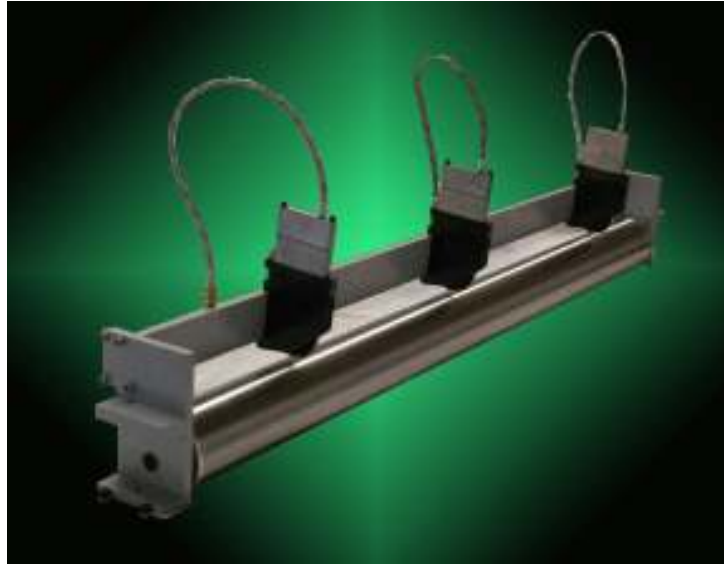

- Ideal for all web-fed converting equipment
- Can incorporate a web guide for increased web accuracy
- For use with all types of materials
- Simple operation-manual adjustments for easy centering of blade to grooved bottom roll or knives
- Custom designed for individual requirements
- Constructed of structural steel weldments for maximum strength and rigidity
- Easily retrofits to existing equipment
- Specially designed mounting frame facilitates installation, operation and maintenance
- Cost effective

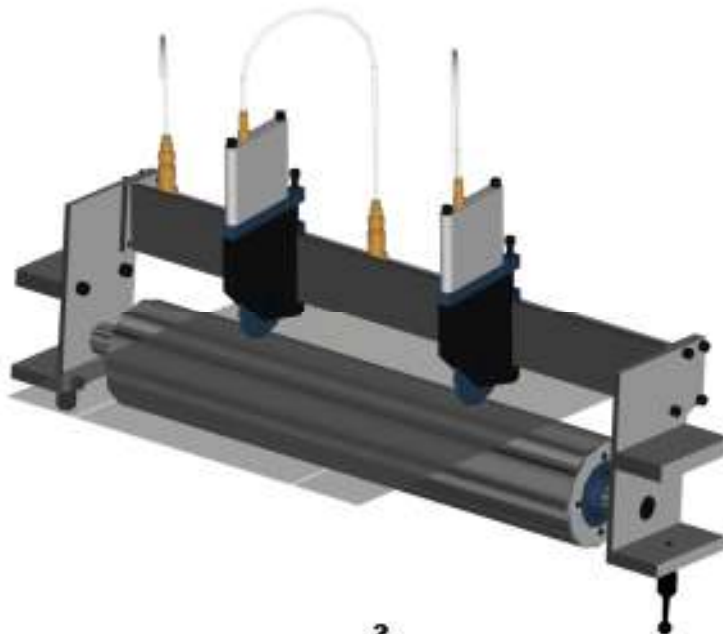



Tried, tested and reliable products for the web-fed industry

- Air shafts and chucks - www.cor-lok.com
- Pneumatic trim and matrix removal systems
www.foxtrimaway.com
- Shaft support systems - www.simplok.com
- Wrinkle removal systems - www.cacwrinklestop.com
- Unwind / rewind systems
www.converteraccessory.com/products/roll_support
- Modular slitting systems
www.converteraccessory.com/products/slitting
- Brakes and clutches
www.converteraccessory.com/products/related/brake
- Roll Handling
www.converteraccessory.com/products/roll_lifting
- Dancer Roll Assemblies
www.converteraccessory.com/products/dancer
- Slitting - www.converteraccessory.com/products/slitting
- Idlers - www.converteraccessory.com/products/related/mainidler
- Custom Equipment
www.converteraccessory.com/products/related

Visit us at www.converteraccessory.com/salesrep
for your local sales representative or
contact us direct

CONVERTER ACCESSORY CORPORATION
201 Alpha Road PO Box 188, Wind Gap, PA 18091-0188
www.converteraccessory.com

Email: sales@converteraccessory.com

Phone: ●800-433-2413 ● 610-863-6008

Fax: ●800-709-1007 ● 610-863-7818

Web Handling Technology . . . CAC Engineered and Manufactured